

SPECIFICATION

Product : Topview 5450 White SMD LED (Z1A Rank)

Part No. : IWS-S5552-PW-K1

Date : 2012. 09. 24 Ver. 1.0

| Proposed By | Checked By | Checked By | Checked By | Approval |
|-------------|------------|------------|------------|----------|
| 결재완료 | | | | |

Comment

ITSWELL 

ITSWELL Co., Ltd
58B-4L, 626-3 Gojan-dong, Namdong-gu, Incheon 405-817 KOREA
TEL:+82-32-813-1801, FAX:+82+32-816-1900
URL: <http://www.itswell.com>

Topview 5450 SMD LED

IWS-S5552-PW-K1 (Z1A Rank)



1. Features

- 1 Chip High-Luminosity SMD LED
- 5.4 x 5.0 x 1.1 mm (L x W x H), 2-Pin, Small Size Surface Mount Type
- Wide Viewing Angle
- Long Operating Life

2. Applications

- Automotive: Backlight in Dashboard and Switch
- Lighting Device: Indicator, General Lighting
- Camera Flash, Hand Carrier Flash
- General Use

3. Outline Drawing and Dimension

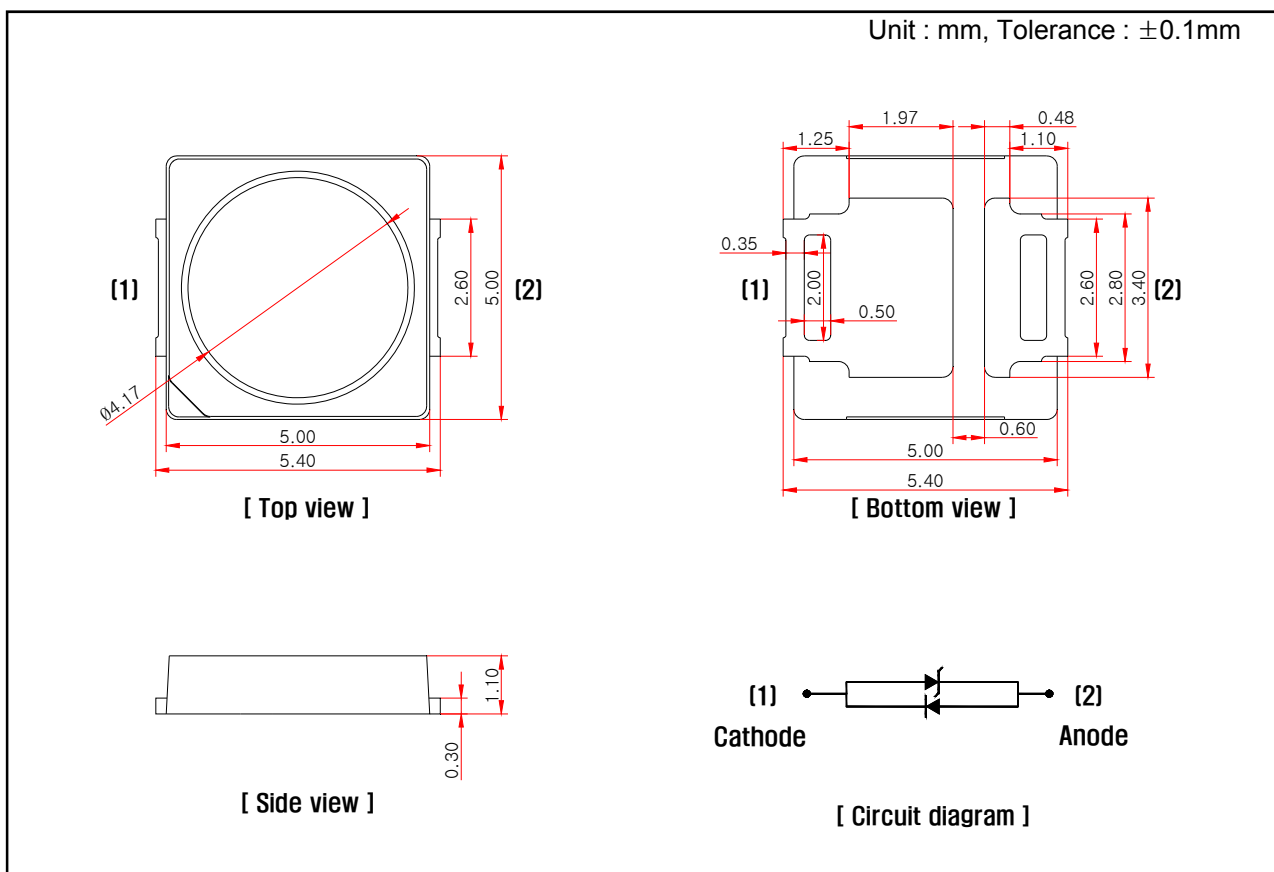

Note

1. All dimensions are in millimeters
2. All dimensions without tolerances are for reference only

4. Absolute Maximum Ratings($T_a = 25\text{ }^\circ\text{C}$)

| Parameter | Symbol | Value | Unit |
|------------------------------------|-----------|------------|------------------|
| Power Dissipation | P_d | 510 | mW |
| Continuous Forward Current | I_F | 150 | mA |
| Peak Forward Current ^{*1} | I_{FP} | 300 | mA |
| Operating Temperature | T_{opr} | -30 ~ 85 | $^\circ\text{C}$ |
| Storage Temperature | T_{stg} | -40 ~ 100 | $^\circ\text{C}$ |
| Soldering Temperature | T_{sol} | 260 (5sec) | $^\circ\text{C}$ |

*1 Duty ratio = 1/10, Pulse width = 0.1ms

5. Electro-optical Characteristics($T_a = 25\text{ }^\circ\text{C}$)

| Parameter | Symbol | Conditions | Min. | Typ. | Max. | Unit. |
|---------------------------------|-----------------|-----------------------|---------------------------------|------|------|----------|
| Forward Voltage | V_F | $I_F = 150\text{mA}$ | 3.0 | - | 3.4 | V |
| Reverse Voltage | V_R | $I_R = 5\text{ mA}$ | 0.7 | 0.8 | 1.5 | V |
| Luminous Flux ^{*2} | Φ_V | $I_F = 150\text{mA}$ | 50 | - | 72 | lm |
| Color Coordinates ^{*3} | CIE x CIE y | $I_F = 150\text{ mA}$ | Refer to Color Coordinates Rank | | | |
| Viewing Angle ^{*4} | $2\theta_{1/2}$ | $I_F = 150\text{ mA}$ | - | 125 | - | $^\circ$ |

*2 Luminous Flux is tested by a tester calibrated by CAS 140B(CIE LED_B) and has an accuracy of 10%

*3 Color Coordinates has an accuracy of ± 0.01 .

*4 Viewing Angle is the angle until 50% of brightness measured from the front part of LED.

5.1 Luminous Flux Rank

| Rank | Luminous Flux (lm) |
|------|--------------------|
| M | 50 ~ 60 |
| N | 60 ~ 72 |

5.2 Forward Voltage Rank

| Rank | Forward Voltage (V) |
|------|---------------------|
| 2 | 3.0 ~ 3.1 |
| 3 | 3.1 ~ 3.2 |
| 4 | 3.2 ~ 3.3 |
| 5 | 3.3 ~ 3.4 |

Topview 5450 SMD LED

IWS-S5552-PW-K1 (Z1A Rank)



5.3 Color Coordinates Rank ($I_F = 150 \text{ mA}$, $T_a = 25 \text{ }^\circ\text{C}$)

| Z1A | |
|--------|--------|
| x | y |
| 0.3121 | 0.3041 |
| 0.3052 | 0.3441 |
| 0.3198 | 0.3585 |
| 0.3229 | 0.3142 |

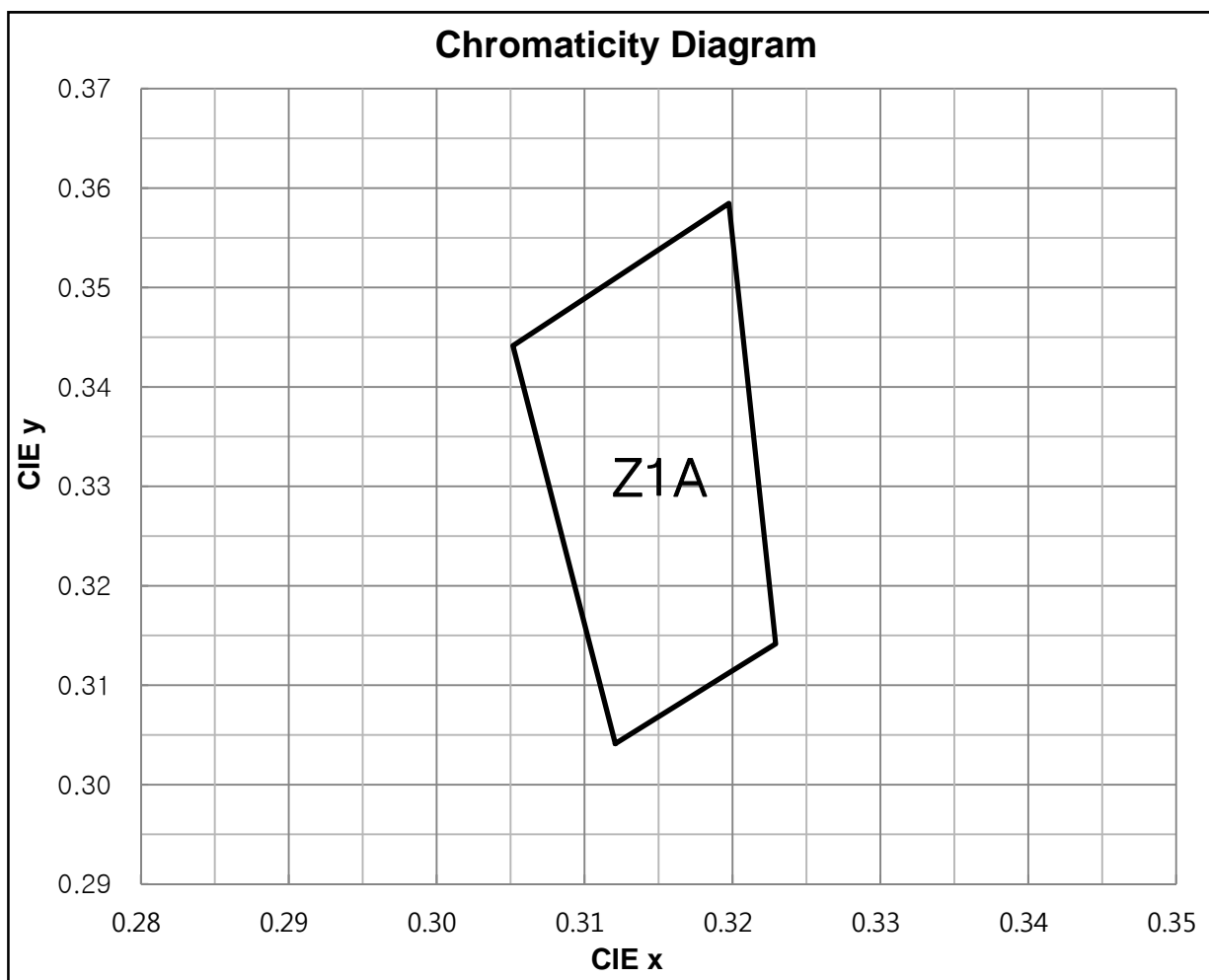

6. Typical Characteristics Curves

Forward Current vs. Forward Voltage

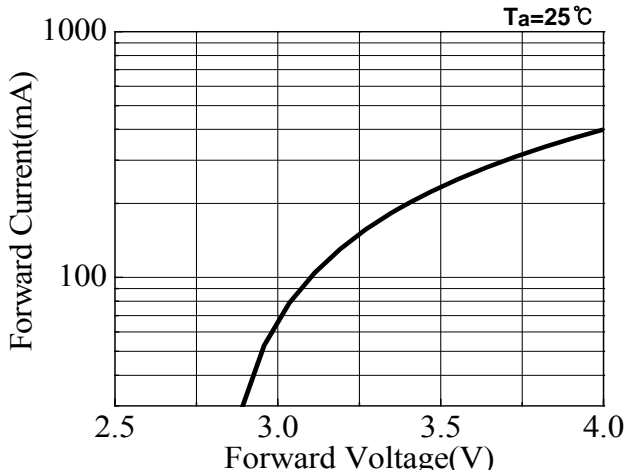

Forward Current vs. Ambient Temperature

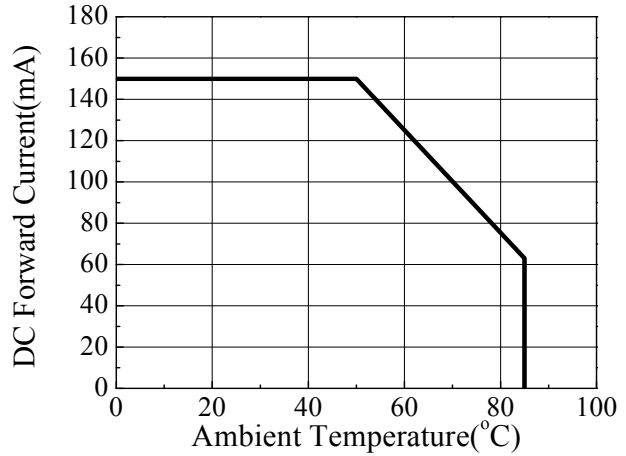

Relative Luminous Intensity vs. Ambient Temperature

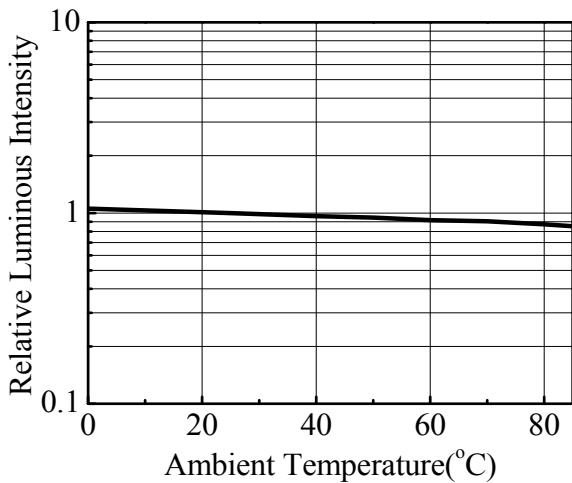

Relative Luminous Intensity vs. Forward Current

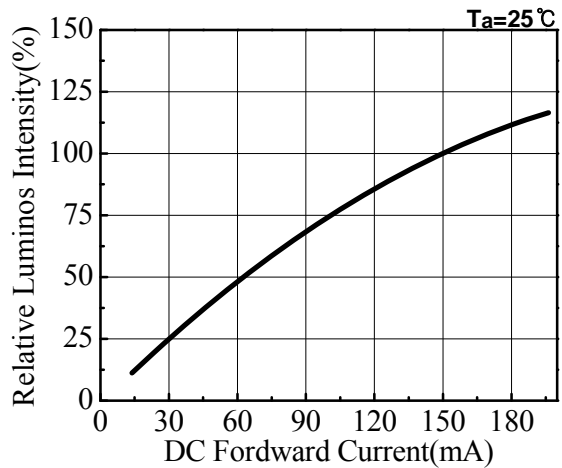

Relative Intensity vs. Wavelength

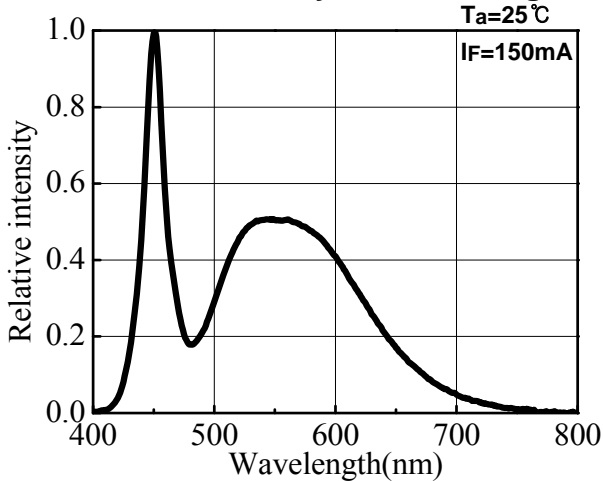

Radiation Diagram

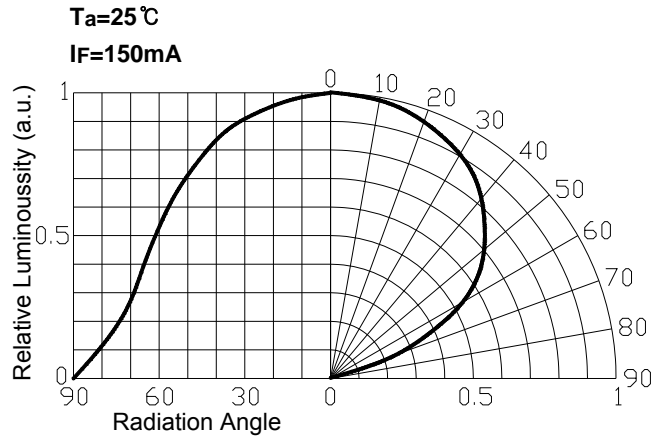

Topview 5450 SMD LED IWS-S5552-PW-K1 (Z1A Rank)



7. Dimension of Tape / Reel

7.1 Tape Dimension

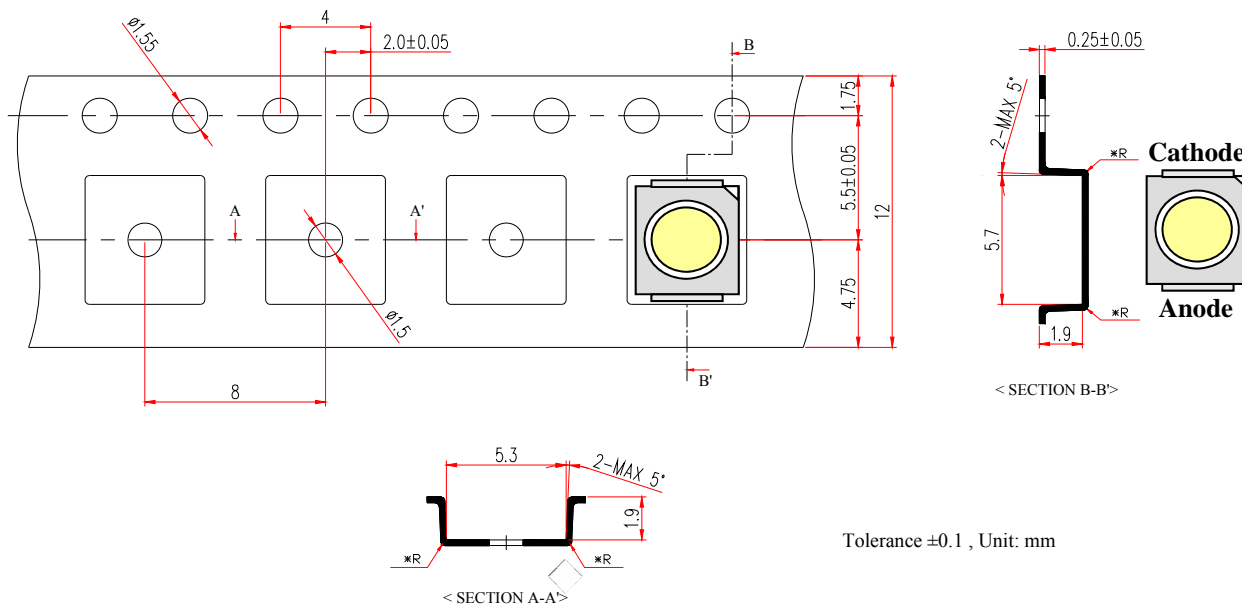

7.2 Reel Dimension

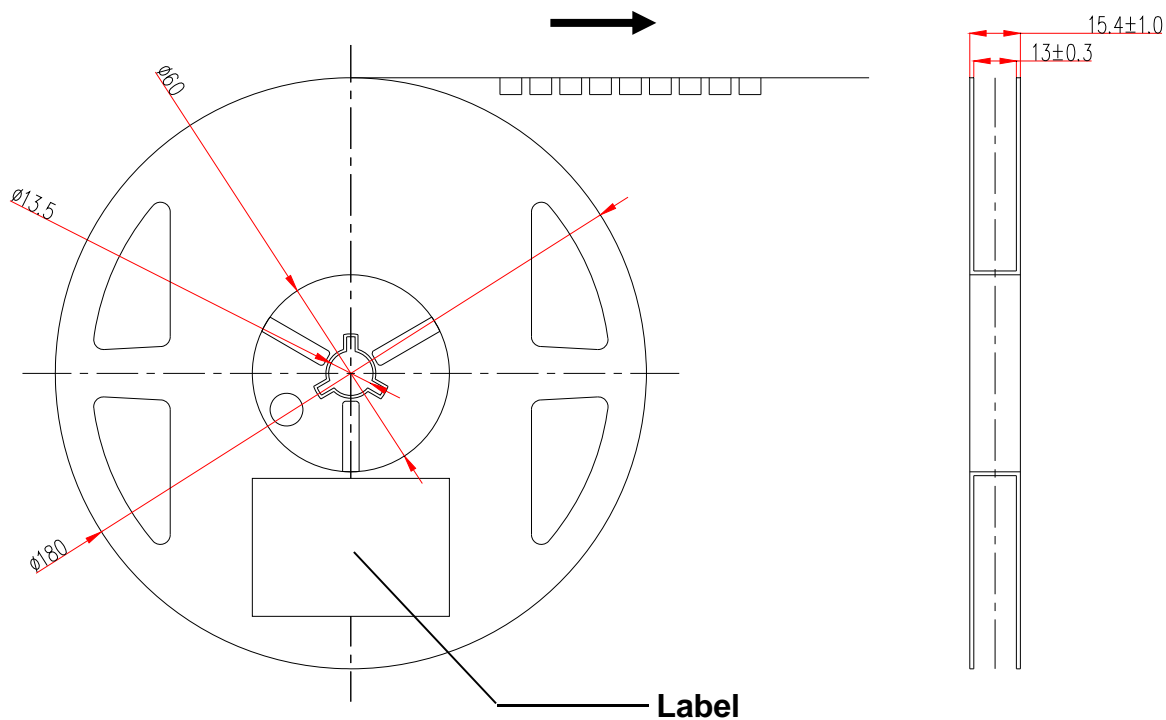

Topview 5450 SMD LED IWS-S5552-PW-K1 (Z1A Rank)



8. Packing Dimension

Unit :mm

Reel

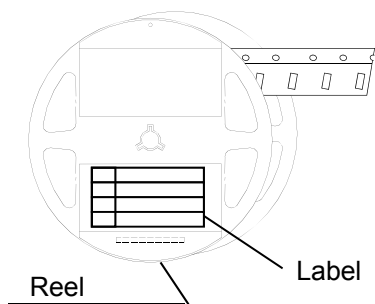

Bake: 60°C, 48hrs



Aluminum Shield Bag

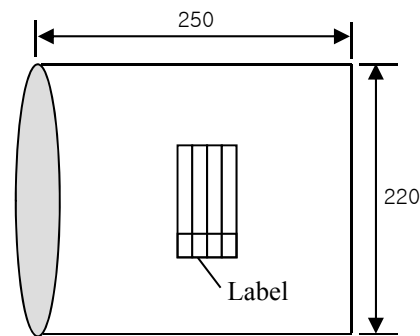

Including Silica gel in a bag



Card Board Box

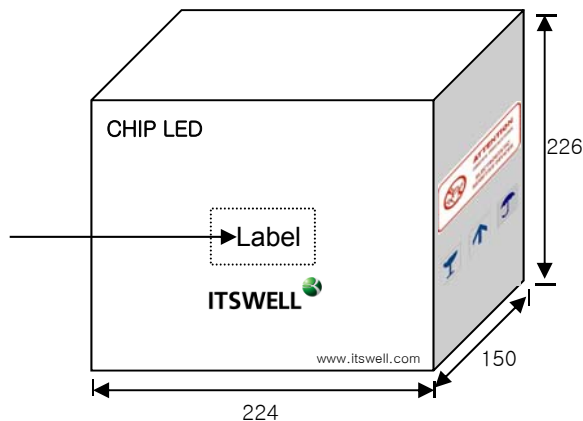

Al Pack Label, Reel Label (70 × 37)

| | | | | |
|-----------------------|-----------------|-----|-----|-----|
| | | | | |
| Lot : | IWS-S5552-PW-K1 | | | |
| | MIN | AVG | MAX | STD |
| V _F [Volt] | | | | |
| Φ _v [lm] | | | | |
| CCT[K] | | | | |
| Q'ty : | yyyy/mm/dd | | | |

| | Dimensions (mm) | Reel / Box | Total Q'ty / Box(pcs) |
|----------------|-----------------------|------------|-----------------------|
| Reel | Φ180mm, 15mm Width | - | 1,000 Max |
| Al Shield Bag | 250x220 | - | 1,000 Max |
| Card Board Box | 224x150x226 | 9 Max | 9,000 Max |

9. Precaution in Use

9.1 Soldering Conditions

- When soldering Power SMD, Heat may affect the electrical and optical characteristics of the LEDs.
- In soldering, do not stress the lead frame and the resin part under the high temperature.
- The silicone part should be protected from mechanical stress or vibration until the Power SMD return to room temperature after soldering.
- Preliminary heating to be at 120~150 °C max. for 120 Seconds max.
- Soldering heat to be at 260 °C max. for 5 sec. Max.
- For manual Soldering is Not more than 3 sec @MAX 350 °C, under soldering iron

< Lead Free >

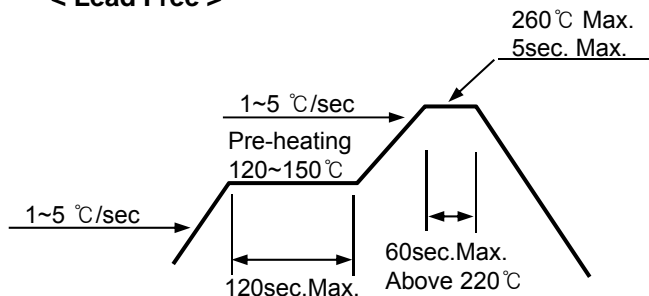

<Recommendable Soldering Pattern>

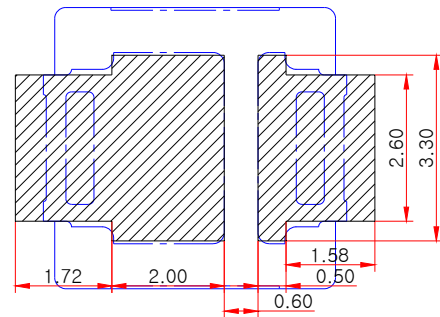

<Unit: mm>

9.2 Storage

- Before opening the package, the LEDs should be kept at 30 °C or less and 70%RH or less.
- After opening the package, the LEDs should be kept at 30 °C or less and 30%RH or less.
- If the moisture absorbent material (silicagel) has faded away or the LED have exceeded the storage time, baking treatment should be performed using the following conditions.
Baking treatment: 60 °C ±5 for 48 hours.

9.3 Static Electricity

- Static electricity or surge voltage damages the Power SMD . It is recommended that a wrist band or an anti-electrostatic glove be used when handling the LEDs.
- A tip soldering iron is requested to be grounded. An ionizer should also be installed where risk of static.
- All devices, equipment and machinery must be properly grounded (via 1MΩ). It is recommended that measures be taken against surge voltage to the equipment that mounts the Power SMD.

9.4 Cleaning

- Isopropyl Alcohol or Ethylene Alcohol is recommended in 5 minutes at room temperature. Don't use unspecified chemical may cause crack or haze on the surface of the epoxy resin.
- Before cleaning, a pre-test should be done to confirm whether any damage to the LED will occur.
- Freon solvents should not be used to clean the LEDs because of worldwide regulations.

9.5 Heat Generation

- When the LEDs are illuminating, operating current should be decided after being considering the ambient maximum temperature.
- Please consider the heat generation of the LED when it is designed the PCB.

9.6 Handling LED

- When handling the LED with tools like Tweezer or Nipper, do not apply Mechanical Forces directly on LED's Surface.



- Do not touch with hand LED surface directly . It may contaminate the surface and affect on optical characteristics.



- LED should be handled from side because LED's molding material may be damaged with scratching on surface, piercing molding material and broking wire.



10. Reliability

10.1 Reliability Test Item

| Test Items | Test Conditions | Notes |
|---|-------------------------------------|-------|
| High Temperature Storage | 100℃, 1,000hr. | 0/25 |
| Low Temperature Storage | -40℃, 1,000hr. | 0/25 |
| Temp. Humidity Storage | 60℃, 90% RH, 1,000hr. | 0/25 |
| Steady State Operating life | 25℃, 180mA, 1,000hr. | 0/25 |
| High Temperature Operating Life | 85℃, 75mA, 1,000hr | 0/25 |
| Low Temperature Operating Life | -30℃, 150mA, 1,000hr. | 0/25 |
| Steady State Operating life Of High Humidity Heat | 60℃, 90% RH, 112.5mA, 1,000hr. | 0/25 |
| Thermal Shock | -40℃(30min)→100℃(30min.), 100 cycle | 0/20 |
| ESD | HBM, 100 pF, 1.5K ohm, 3 times | 0/20 |

10.2 Criteria for Judging the Damage

| Items | Test Conditions | Criteria for judgment |
|----------------------------|----------------------|----------------------------|
| Luminous Flux (Φ_V) | $I_F = 150\text{mA}$ | > 70% of S |
| Forward Voltage (V_F) | $I_F = 150\text{mA}$ | Less than $\pm 110\%$ of U |

* U means the upper limit of specified characteristics, S means initial value.

Topview 5450 SMD LED

IWS-S5552-PW-K1 (Z1A Rank)



11. Part Name Description

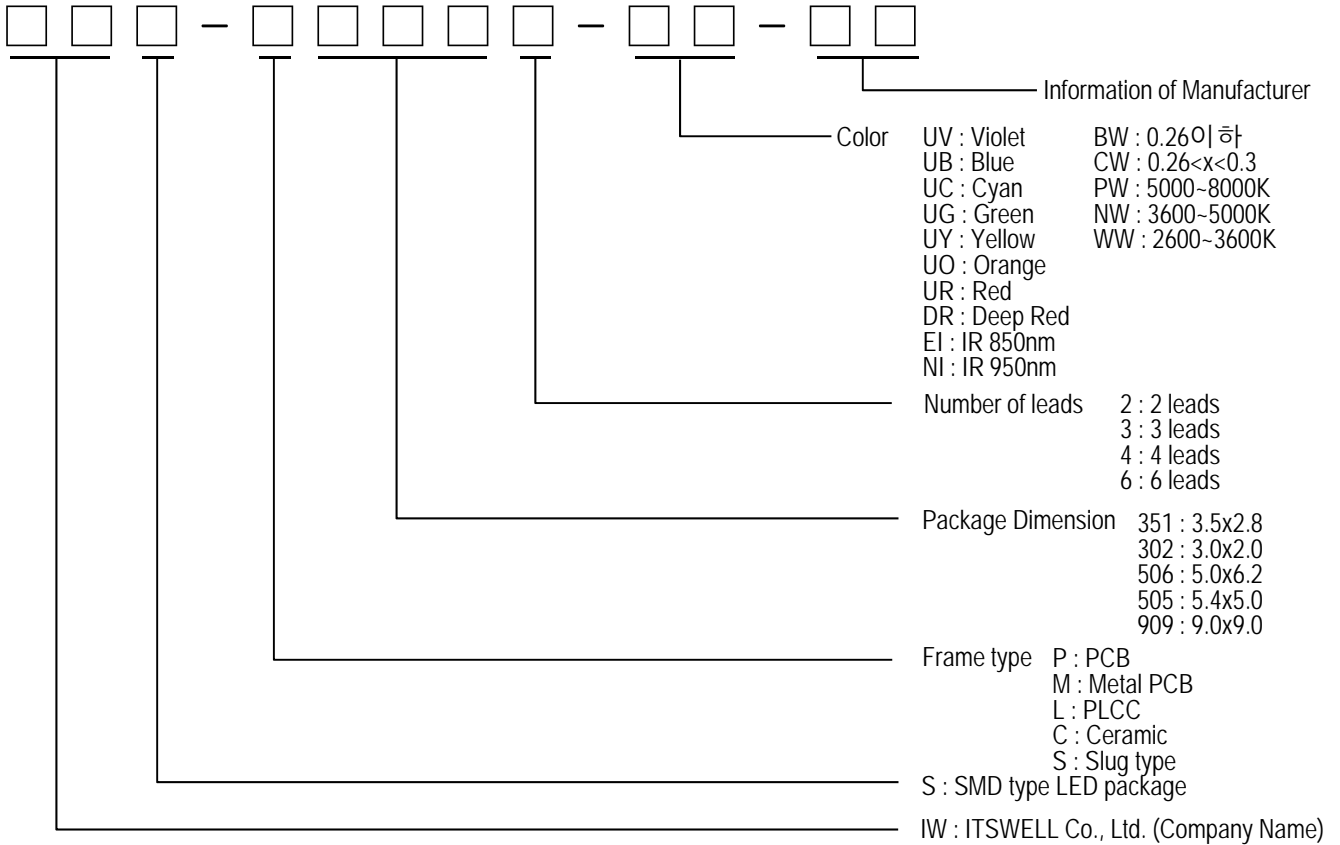

12. Rank Description

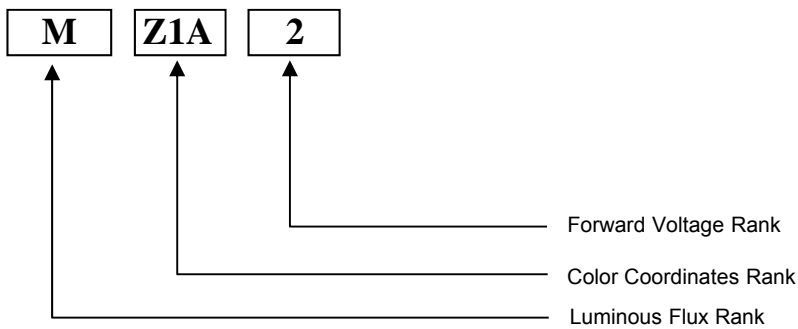

13. Attention : Electric Static Discharge (ESD) Protection



The symbol shown on the page herein to introduce 'Electro-Optical Characteristics'. ESD protection for GaP and AlGaAs based chips is still Necessary even though they are safe in low static-electric discharge. Material in AlInGaP, GaP, or/and InGaN based chips are STATIC SENSITIVE devices. ESD protection has to considered and taken in the initial design stage. If manual work/process is needed, please ensure the device is well protective from ESD during all the process.

