

# SPECIFICATION

Product : Topview 5450 Red SMD LED

Part No. : IWS-S5556-UR-K1 (0.5W)

Date : 2012. 05. 16 Ver. 1.0

Proposed By	Checked By	Checked By	Checked By	Approval
결 재 완 료				

Comment

ITSWELL 

ITSWELL Co., Ltd  
58B-4L, 626-3 Gojan-dong, Namdong-gu, Incheon 405-817 KOREA  
TEL:+82-32-813-1801, FAX:+82+32-816-1900  
URL: <http://www.itswell.com>,



### 4. Absolute Maximum Ratings( $T_a = 25\text{ }^\circ\text{C}$ )

Parameter	Symbol	Value	Unit
Power Dissipation	$P_d$	360	mW
Continuous Forward Current	$I_F$	150	mA
Peak Forward Current <sup>*1</sup>	$I_{FP}$	300	mA
Operating Temperature	$T_{opr}$	-30 ~ 85	$^\circ\text{C}$
Storage Temperature	$T_{stg}$	-40 ~ 100	$^\circ\text{C}$
Soldering Temperature	$T_{sol}$	260 (5sec)	$^\circ\text{C}$

\*1 Duty ratio = 1/10, Pulse width = 0.1ms

### 5. Electro-optical Characteristics( $T_a = 25\text{ }^\circ\text{C}$ )

Parameter	Symbol	Conditions	Min.	Typ.	Max.	Unit.
Forward Voltage	$V_F$	$I_F = 150\text{mA}$	1.8	-	2.4	V
Reverse Current	$I_R$	$V_R = 5\text{V}$	-	-	10	$\mu\text{A}$
Luminous Flux <sup>*2</sup>	$\Phi_V$	$I_F = 150\text{mA}$	8	-	20	lm
Color Coordinates <sup>*3</sup>	CIE x CIE y	$I_F = 150\text{mA}$	Refer to Color Coordinates Rank			
Viewing Angle <sup>*4</sup>	$2\theta_{1/2}$	$I_F = 150\text{mA}$	-	125	-	$^\circ$

\*2 Luminous Intensity is tested by a tester calibrated by CAS 140B(CIE LED\_B) and has an accuracy of 10%

\*3 Color Coordinates has an accuracy of  $\pm 0.01$ .

\*4 Viewing Angle is the angle until 50% of brightness measured from the front part of LED.

#### 5.1 Luminous Flux Rank

Rank	Luminous Flux (lm)
B	8 ~ 10
C	10 ~ 12
D	12 ~ 14
E	14 ~ 17
F	17 ~ 20

#### 5.2 Forward Voltage Rank

Rank	Forward Voltage (V)
1	1.8 ~ 2.4

#### 5.3 Dominant Wavelength Rank

Rank	Dominant Wavelength (nm)
a	615 ~ 635

### 6. Typical Characteristics Curves

**Forward Current vs. Forward Voltage**

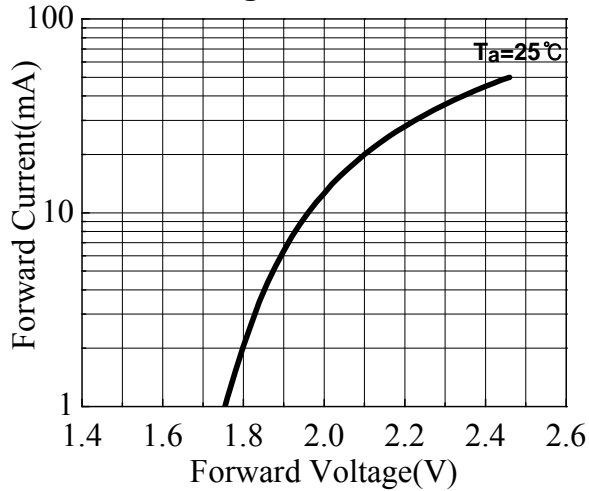

**Forward Current vs. Ambient Temperature**

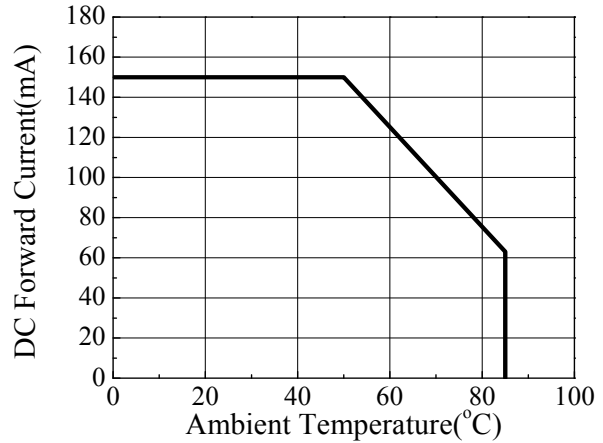

**Relative Luminous Intensity vs. Ambient Temperature**

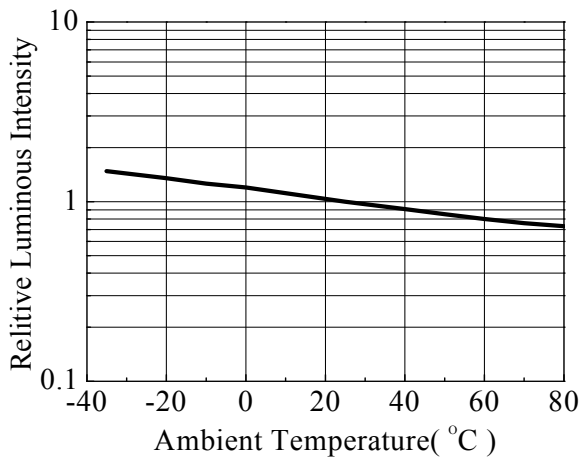

**Relative Luminous Intensity vs. Forward Current**

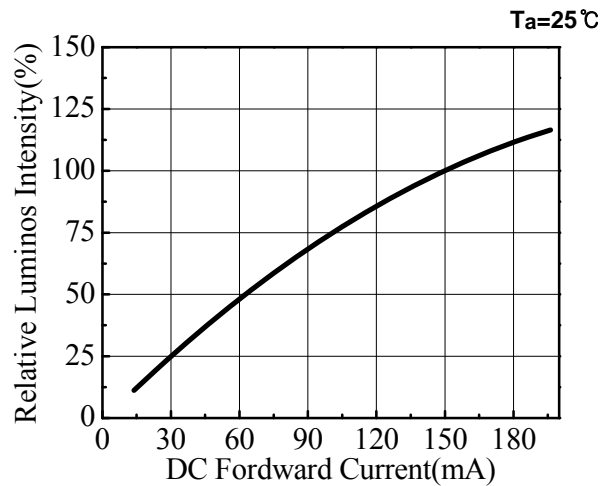

**Relative Intensity vs. Wavelength**

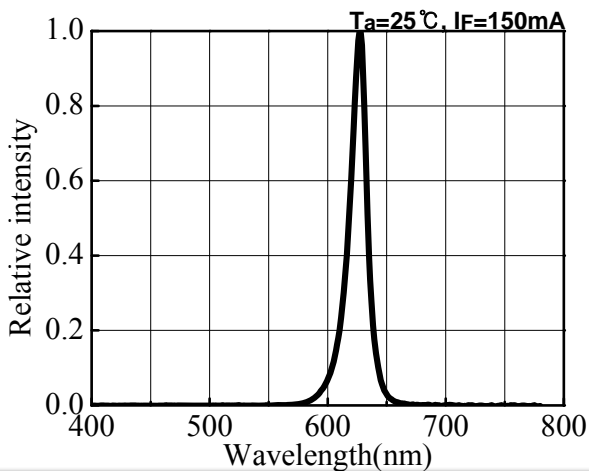

**Radiation Diagram**

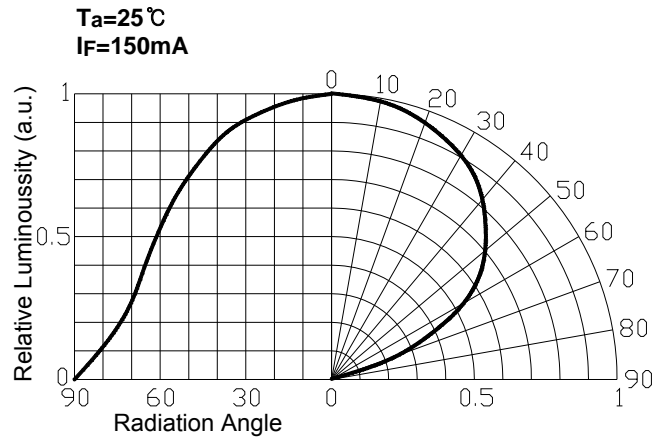

# Topview 5450 SMD LED IWS-S5556-UR-K1



## 7. Dimension of Tape / Reel

### 7.1 Tape Dimension

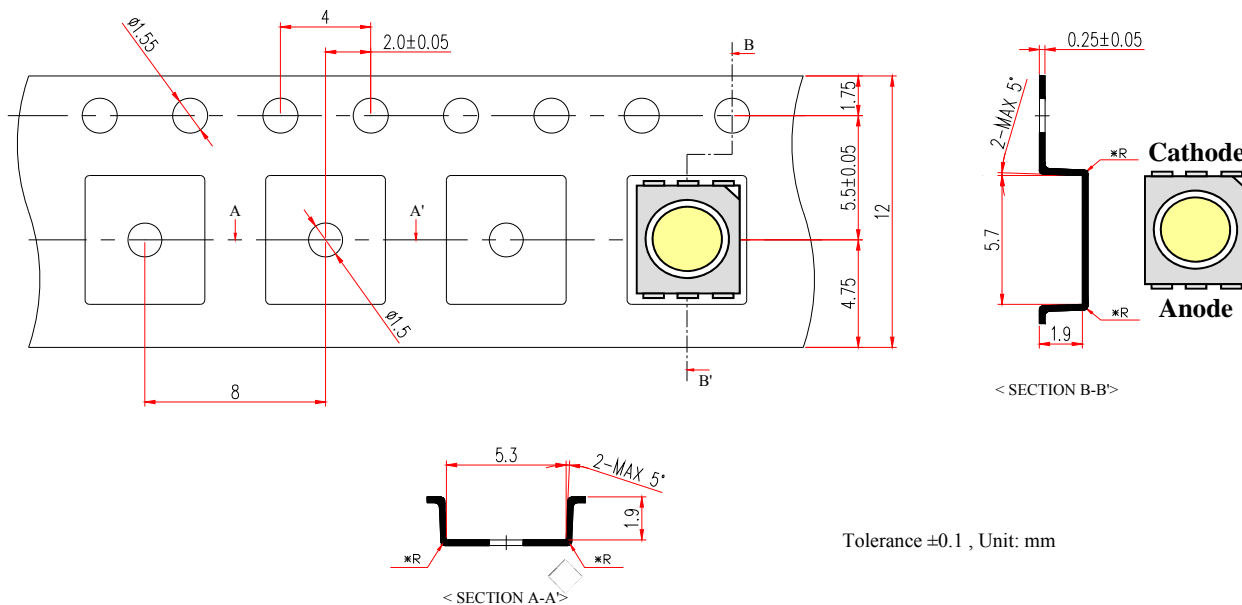

### 7.2 Reel Dimension

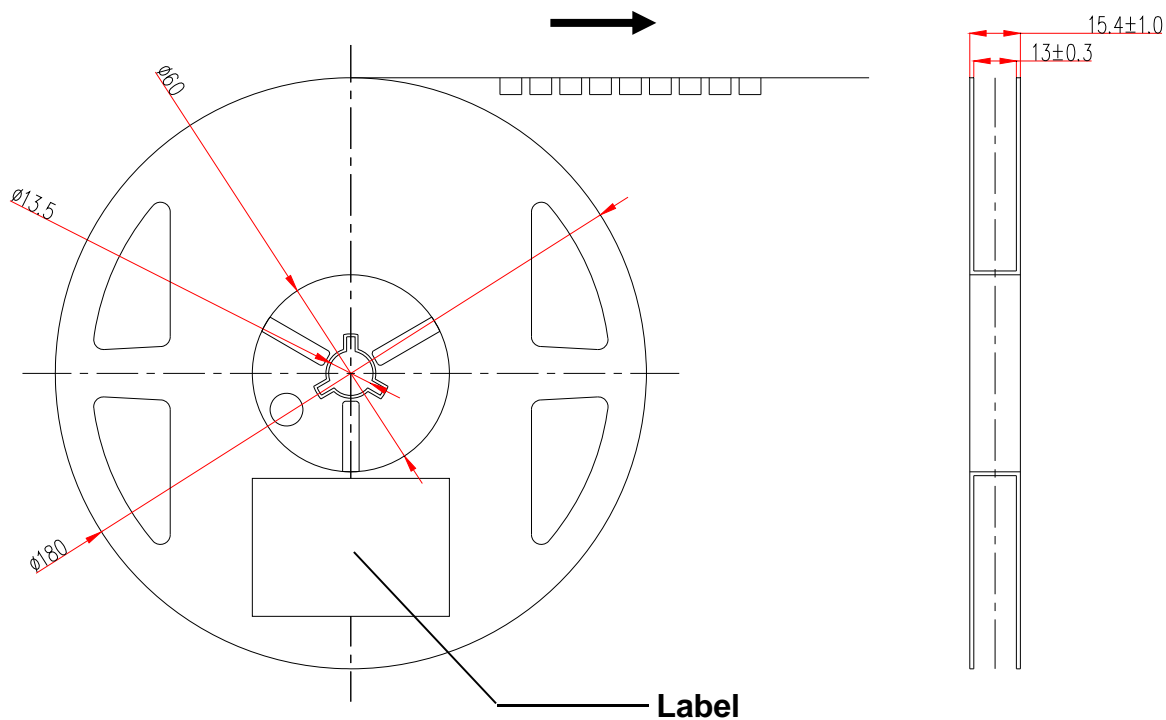

# Topview 5450 SMD LED IWS-S5556-UR-K1



## 8. Packing Dimension

Unit :mm

**Reel**

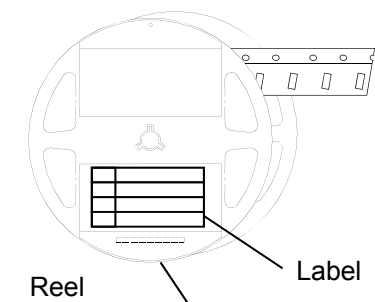

**Aluminum Shield Bag**

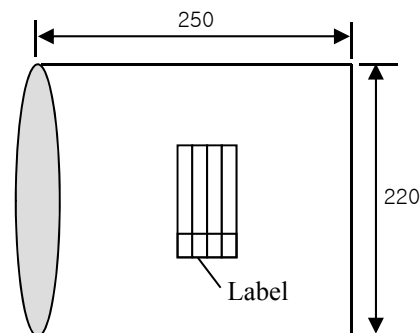

Bake: 60°C, 48hrs



Including Silica gel in a bag



**Card Board Box**

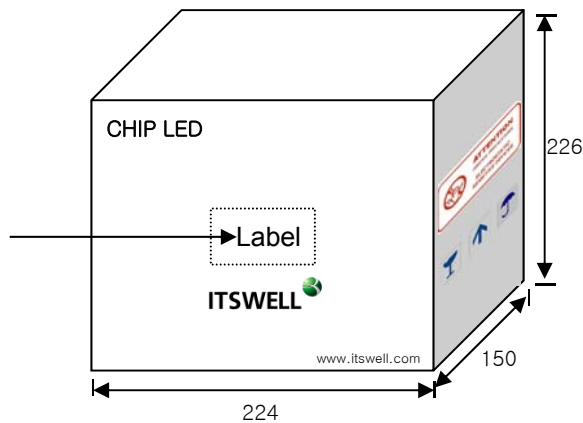

**Al Pack Label, Reel Label** (70 × 37)

<b>ITSWELL</b>				
Lot :	IWS-S5556-UR-K1			
	MIN	AVG	MAX	STD
V <sub>F</sub> [Volt]				
Φ <sub>v</sub> [lm]				
CIE[x,y]				
Q'ty :	yyyy/mm/dd			

	Dimensions (mm)	Reel / Box	Total Q'ty / Box(pcs)
Reel	Φ180mm, 15mm Width	-	1,000 Max
Al Shield Bag	250x220	-	1,000 Max
Card Board Box	224x150x226	9 Max	9,000 Max

## 9. Precaution in Use

### 9.1 Soldering Conditions

- When soldering Power SMD, Heat may affect the electrical and optical characteristics of the LEDs.
- In soldering, do not stress the lead frame and the resin part under the high temperature.
- The silicone part should be protected from mechanical stress or vibration until the Power SMD return to room temperature after soldering.
- Preliminary heating to be at 120~150 °C max. for 120 Seconds max.
- Soldering heat to be at 260 °C max. for 5 sec. Max.
- For manual Soldering is Not more than 3 sec @MAX 350 °C, under soldering iron

#### < Lead Free >

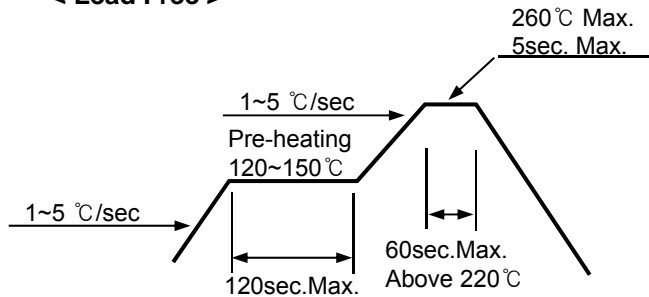

#### <Recommendable Soldering Pattern>

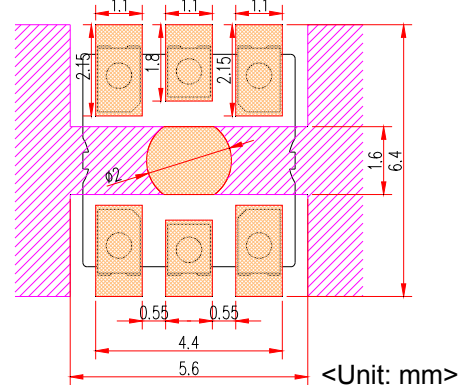

### 9.2 Storage

- Before opening the package, the LEDs should be kept at 30 °C or less and 70%RH or less.
- After opening the package, the LEDs should be kept at 30 °C or less and 30%RH or less.
- If the moisture absorbent material (silicagel) has faded away or the LED have exceeded the storage time, baking treatment should be performed using the following conditions.  
Baking treatment: 60 °C ±5 for 48 hours.

### 9.3 Static Electricity

- Static electricity or surge voltage damages the Power SMD . It is recommended that a wrist band or an anti-electrostatic glove be used when handling the LEDs.
- A tip soldering iron is requested to be grounded. An ionizer should also be installed where risk of static.
- All devices, equipment and machinery must be properly grounded (via 1MΩ). It is recommended that measures be taken against surge voltage to the equipment that mounts the Power SMD.

### 9.4 Cleaning

- Isopropyl Alcohol or Ethylene Alcohol is recommended in 5 minutes at room temperature.  
Don't use unspecified chemical may cause crack or haze on the surface of the epoxy resin.
- Before cleaning, a pre-test should be done to confirm whether any damage to the LED will occur.
- Freon solvents should not be used to clean the LEDs because of worldwide regulations.

### 9.5 Heat Generation

- When the LEDs are illuminating, operating current should be decided after being considering the ambient maximum temperature.
- Please consider the heat generation of the LED when it is designed the PCB.

### 9.6 Handling LED

- When handling the LED with tools like Tweezer or Nipper, do not apply Mechanical Forces directly on LED's Surface.

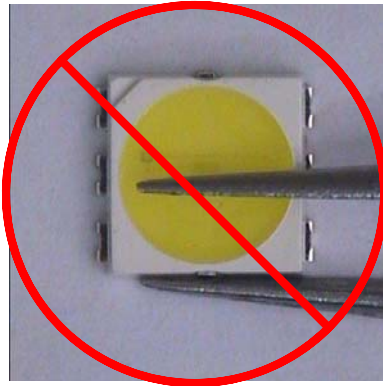

- Do not touch with hand LED surface directly . It may contaminate the surface and affect on optical characteristics.



- LED should be handled from side because LED's molding material may be damaged with scratching on surface, piercing molding material and broking wire.

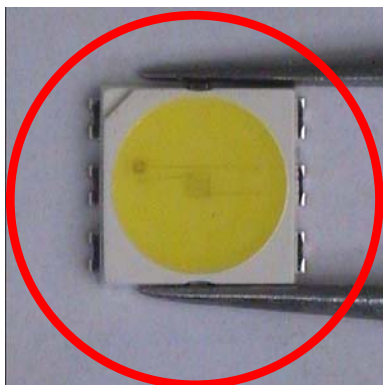



## 10. Reliability

### 10.1 Reliability Test Item

Test Items	Test Conditions	Notes
High Temperature Storage	100℃, 1,000hr.	0/25
Low Temperature Storage	-40℃, 1,000hr.	0/25
Temp. Humidity Storage	60℃, 90% RH, 1,000hr.	0/25
Steady State Operating life	25℃, 180mA, 1,000hr.	0/25
High Temperature Operating Life	85℃, 63mA, 1,000hr	0/25
Low Temperature Operating Life	-30℃, 150mA, 1,000hr.	0/25
Steady State Operating life Of High Humidity Heat	60℃, 90% RH, 113mA, 1,000hr.	0/25
Thermal Shock	-40℃(30min)→100℃(30min.), 100 cycle	0/20
ESD	HBM, 100 pF, 1.5K ohm, 3 times	0/20

### 10.2 Criteria for Judging the Damage

Items	Test Conditions	Criteria for judgment
Luminous Flux ( $\Phi_V$ )	$I_F = 150\text{mA}$	> 70% of S
Forward Voltage ( $V_F$ )	$I_F = 150\text{mA}$	Less than $\pm 110\%$ of U

\* U means the upper limit of specified characteristics, S means initial value.

# Topview 5450 SMD LED

## IWS-S5556-UR-K1



### 11. Part Name Description

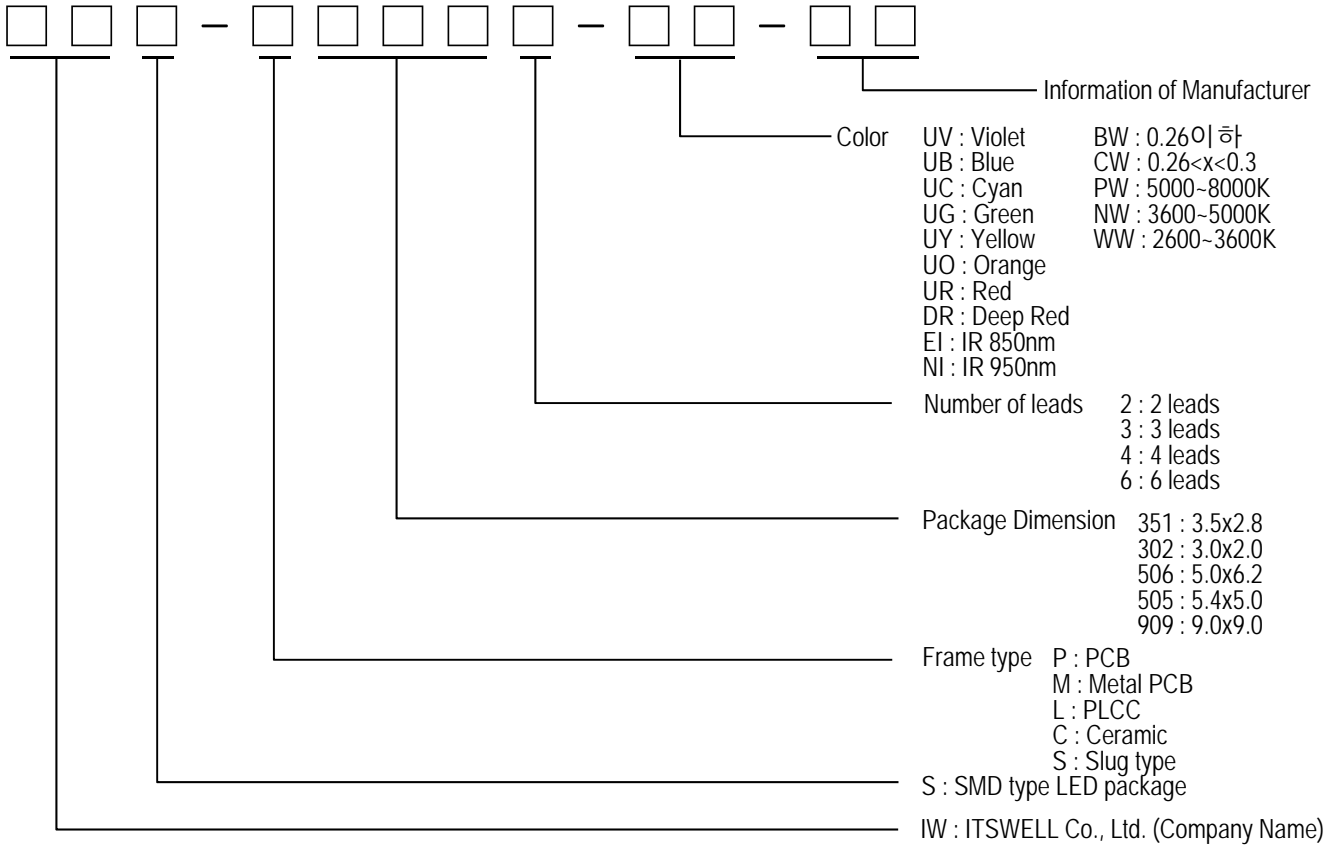

### 12. Rank Description

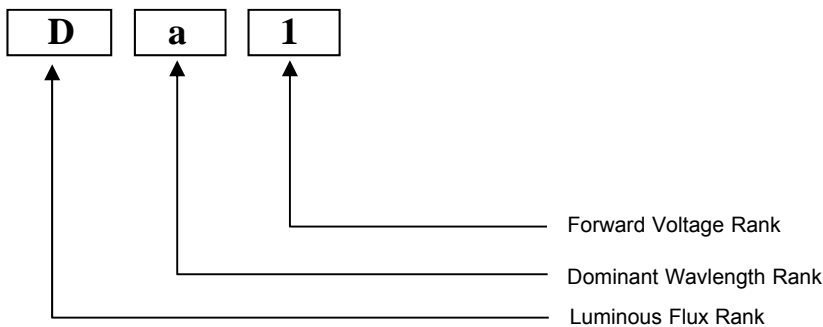

### 13. Attention : Electric Static Discharge (ESD) Protection



The symbol shown on the page herein to introduce 'Electro-Optical Characteristics'. ESD protection for GaP and AlGaAs based chips is still Necessary even though they are safe in low static-electric discharge. Material in AlInGaP, GaP, or/and InGaN based chips are STATIC SENSITIVE devices. ESD protection has to considered and taken in the initial design stage. If manual work/process is needed, please ensure the device is well protective from ESD during all the process.

